

## DCS 1800M 80W Power Amplifier Module Specification (PAD18080ADA)

### 1. *Electrical specifications*

No.	Parameter	Specification	Unit	Remark
1.1	Signal	DCS		
1.2	Testing rule	Two tone test, CW signal, carrier spacing 600K	dB	
1.3	Frequency range	1805~1880	MHz	
1.4	Output power	$45 \pm 0.5$	dBm	
1.5	Output power versus temperature	$\pm 1$ @ -40°C ~ +55°C	dB	
1.6	Gain	$49 \pm 1.0$	dB	
1.7	Gain adjusting range	$\geq 30$	dB	Digital attenuator
1.8	Gain adjusting step	1	dB	Digital attenuator
1.9	Gain variation versus frequency	$\leq 1$	dB	
1.10	Gain variation versus temperature	$\pm 2$ @ -40°C ~ +55°C	dB	
1.11	IMD (intermodulation)	$\leq -45$	dBc	CW signal, two tone test, carrier spacing 600K
1.12	DCS EVM @Pout=49dBm	< 2% @ above source own EVM		
1.13	ALC range	$\geq 15$	dB	
1.14	Allowable maximum input power	$\geq 10$	dBm	
1.15	VSWR	Input $\leq 1.5$		
		Output $\leq 1.5$		
1.16	DC power supply	$\leq 7$	A	
1.17	DC supply current	27~29	V	

## 2. Environmental Specifications

No.	Parameter	Condition
2.1	Operating Temperature	-25 °C to +80 °C at location
2.2	Storage Temperature	-40 °C to +85 °C ambient
2.3	Cold Start	-40 °C
2.4	Operating Humidity	5% to 95% relative humidity, non-condensing
2.5	Storage Humidity	5% to 95% relative humidity, non-condensing

## 3. Monitoring & control

No.	Parameter	Description	Remarks
3.1	Serial bus	RS485	
3.2	Reading parameters	Input power, output power, reverse power, VSWR, temperature, ALC level, digital attenuation	
3.3	Setting parameters	Digital attenuation, ALC level,	
3.4	Alarm	High temperature, output power overload, VSWR, PA fault	

## 4. Mechanical specifications

No.	Parameter	Description	Remarks
4.1	Dimensions[L×W×H]	200×150×23 mm <sup>3</sup>	
4.2	Weight	2Kg	
4.3	Mounting	6 M4 screws	
4.4	DC power supply connector	3W3(male)	
4.5	Control connector	DB9(male)	
4.6	Input connector	SMA(female)	
4.7	Output connector	SMA(female)	
4.8	Mark	Show information: power supply, ground, input port, output port, serial number, description etc	

4.9	Surface finish	Sandblast	
-----	----------------	-----------	--

**5. Interface specification**

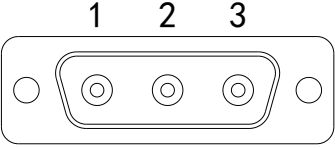
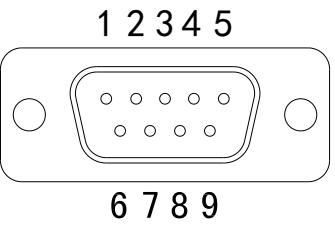
Connector		Pin description		
<b>Power supply connector (3w3)</b>		Pin1: Ground		
		Pin2: 28V		
		Pin3: NC		
<b>Control (DB9)</b>		Pin1:RS485A	Pin2:RS485A	Pin3:RS485B
		Pin4:RS485B	Pin5:Ground	Pin6:NC
		Pin7:NC	Pin8:NC	Pin9:NC

**6. Outside drawing**

